

KIT RADIUS - CANCELLO SEZIONALE
KIT RADIUS - CORNER GATE

Kit di accessori in acciaio zincato per cancelli sezionali

Corner gate kit with galvanised steel accessories

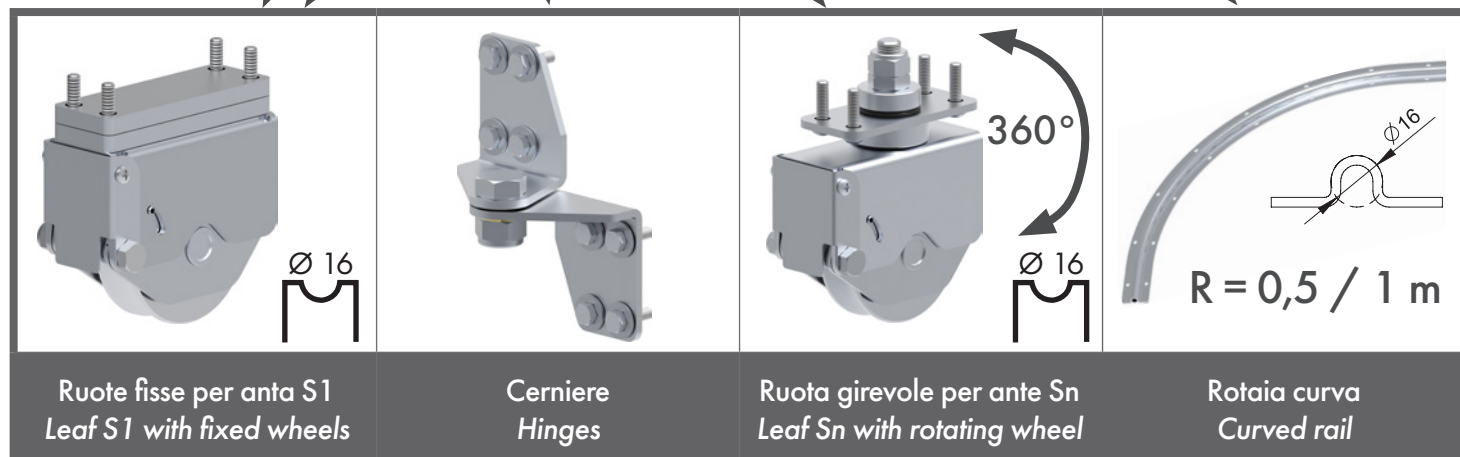
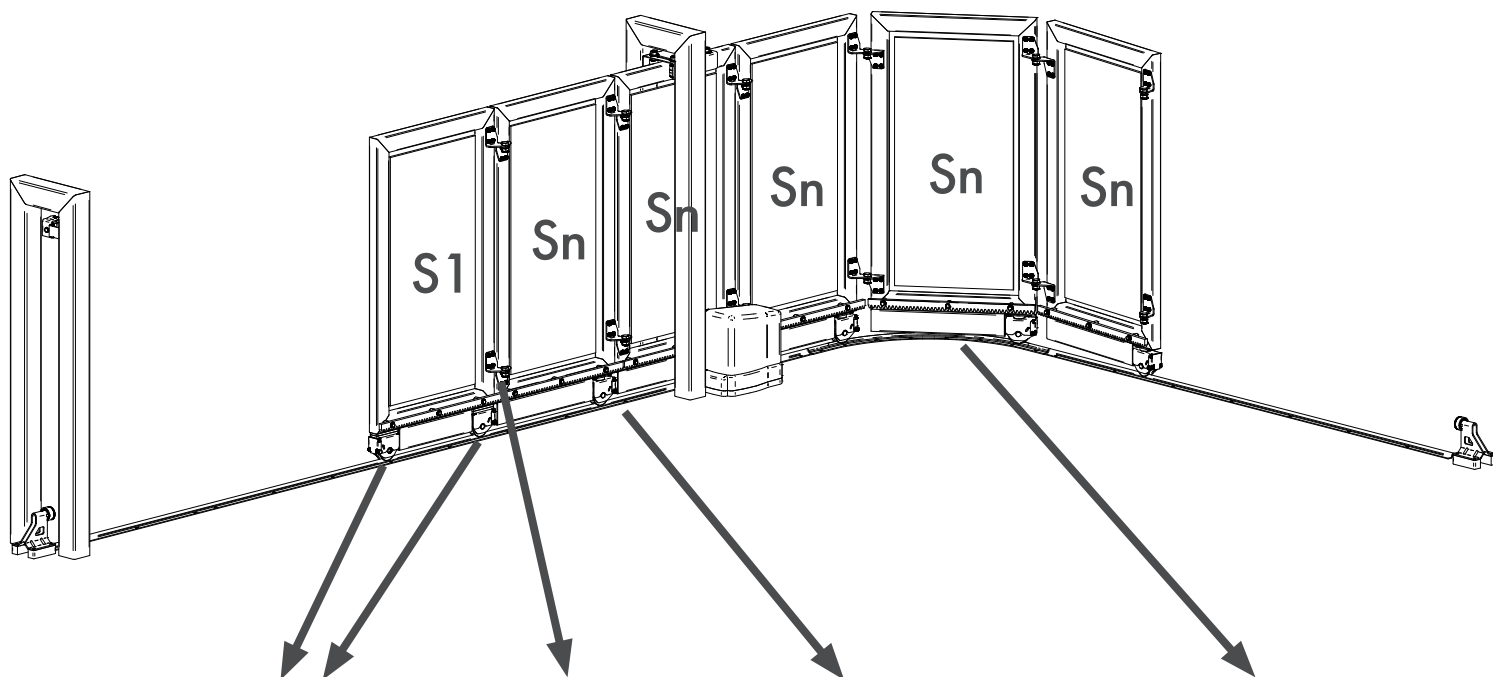

KA8103 KIT ANTA PRINCIPALE S1 / KIT MAIN LEAF S1



<p>KA8103.050</p>	<p>Rotaia curva R 0,50 m / Curved rail R 0,50 m Ante da 0,4 a 0,75 m / Leaves from 0,4 to 0,75 m</p>	<p>R = 0,5m</p>
<p>KA8103.100</p>	<p>Rotaia curva R 1 m / Curved rail R 1 m Ante da 0,4 a 1,5 m / Leaves from 0,4 to 1,5 m</p>	<p>R = 1m</p>

KA8103.001 KIT ANTA SECONDARIA Sn / KIT SECONDARY LEAF

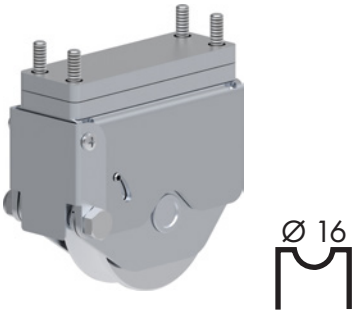
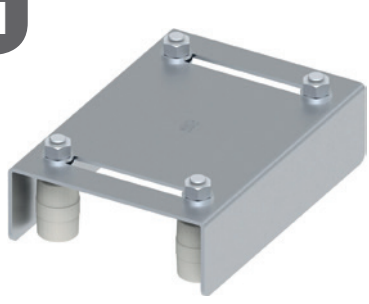

COMPONENTI
COMPONENT LIST

KA8103.050/.100 KIT ANTA PRINCIPALE S1 / KIT MAIN LEAF S1

<p>x2</p>  <p>VA1321.075</p>	<p>x1</p>  <p>VA3205.B40</p>	<p>x2</p>  <p>VA4112.125</p>
<p>x1</p>  <p>R = 0,5 / 1 m</p> <p>VA2312</p>		

KA8103.001 KIT ANTA SECONDARIA S_n / KIT SECONDARY LEAF S_n

<p>x1</p>  <p>VA1322.075</p>	<p>x2</p>  <p>VL4600.135</p>	
---	---	--



ARTICOLI CORRELATI
RELATED ARTICLES





DIMENSIONAMENTO
DIMENSIONING

PESO ANTA LEAF WEIGHT	PESO CANCELLO MAX GATE WEIGHT	SPESSORE TUBOLARE T TUBULAR THICKNESS T
min 15 - max 100 Kg	500 Kg	min 40 - max 80 mm

S1 = Anta principale = sempre 1 PZ
Main Leaf = always 1 PIECE

Sn = Ante secondarie
Secondary leaves

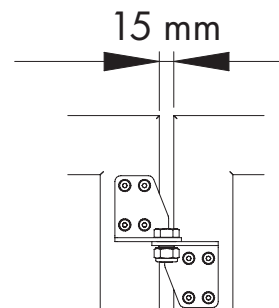
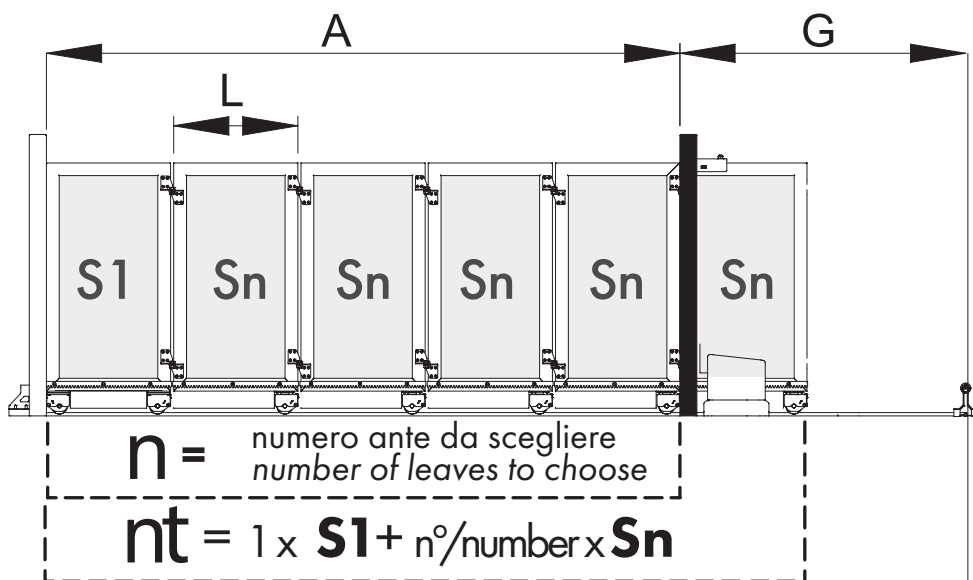

E min 0,35m / max = L

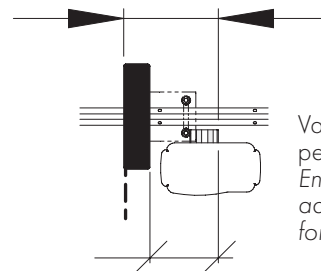

Valutare spazio per il motore
Ensure you leave adequate space for the gate motor

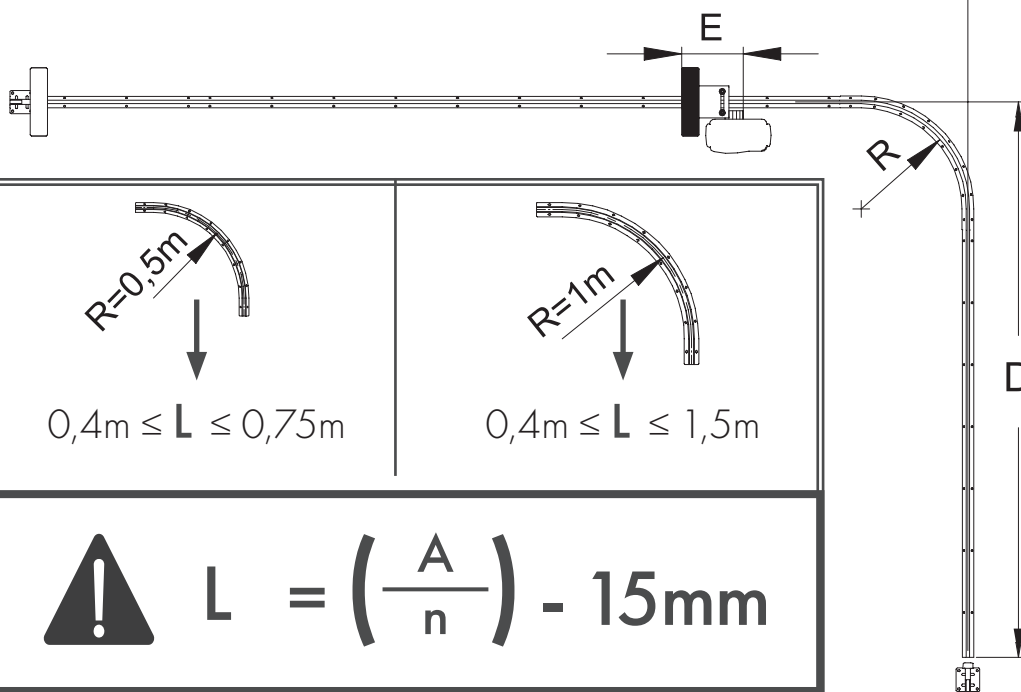

$G = L + E + R$
 $D = A - E - 0,2m$

$G = L + E + R$
 $D = A - E - 0,4m$



Attenzione:

Aumentare o diminuire **n** per ottenere valori **L** compatibili. Valori **G** min. sono ottenibili usando ante corte e rotaia $R=0,5$ ($L \sim 0,4m$ e $E=0,35m$)
D dipende dai valori **A**, **L** e dal raggio **R** scelto

Warning:

Raise or lower **n** to obtain compatible **L** values. Use short leaves and curved rails $R=0,5$ to obtain **G** values ($L \sim 0,4m$ e $E=0,35m$)
D depends on **A-L** values and on the radius **R** chosen

LEGENDA

- A** = apertura / opening
- G** = ingombro posteriore / amount of space behind the opening
- E** = distanza tra il perno del motore e la colonna / distance between the gate motor and column
- R** = raggio curva / radius of curve
- L** = lunghezza anta / leaf length
- D** = ingombro laterale della rotaia / lateral space for the rail
- T** = spessore anta / leaf thickness
- nt** = numero totale di ante / total quantity of leaves



ANTE DA REALIZZARE E ARTICOLI DA ORDINARE
ITEMS TO ORDER TO REALISE YOUR GATE

Anta principale S1
Main leaf S1

1 x

KA8103.050

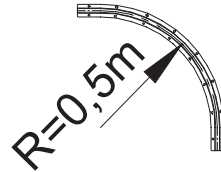

KA8103.100

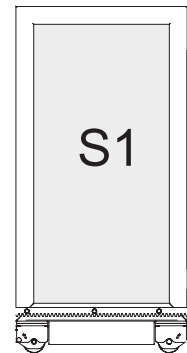
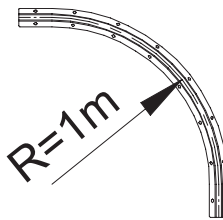

Anta secondaria
Secondary leaf

KA8103.001 x numero di ante Sn
number of leaves Sn

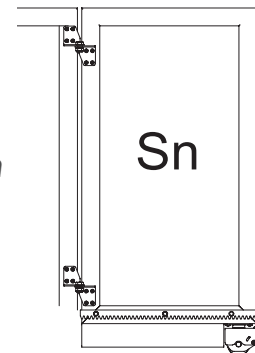



INFO TECNICHE
TECHNICAL INFO

1. Importante: la superficie di lavoro per il cancello sezionale deve essere in piano, priva di dossi o avvallamenti
2. Per cancelli motorizzati è importante fare attenzione al posizionamento, al taglio ed alle misure massime della cremagliera (vedi fig. 7)
3. Per cancelli motorizzati prevedere partenze ed arresti lenti. Velocità max= 0,18m/s

1. Important: the gate working surface must be flat, without bumps or hollows
2. For motorised gates it is important to pay attention to the rack's cut, the positioning and the maximum measurements
3. For motorised gates provide slow starting points and soft stops, with a maximum speed of = 0,18 m/s

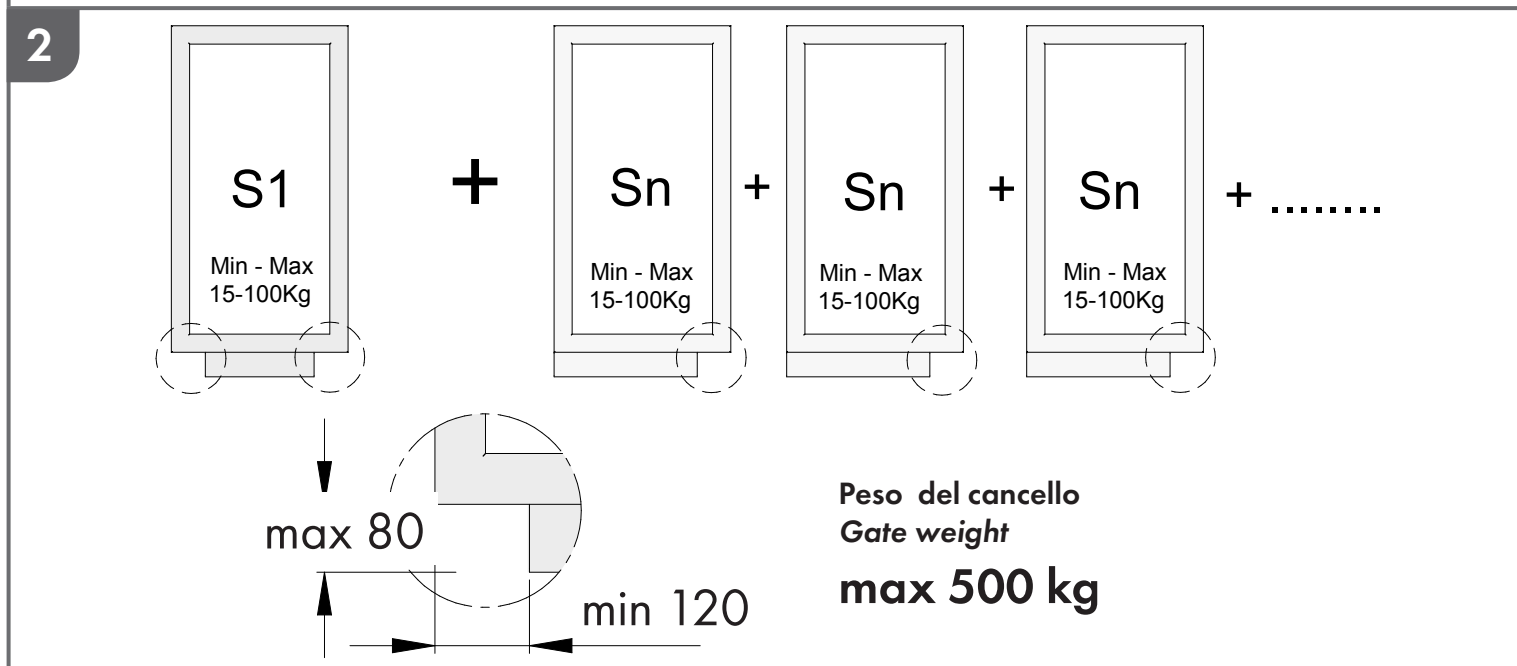
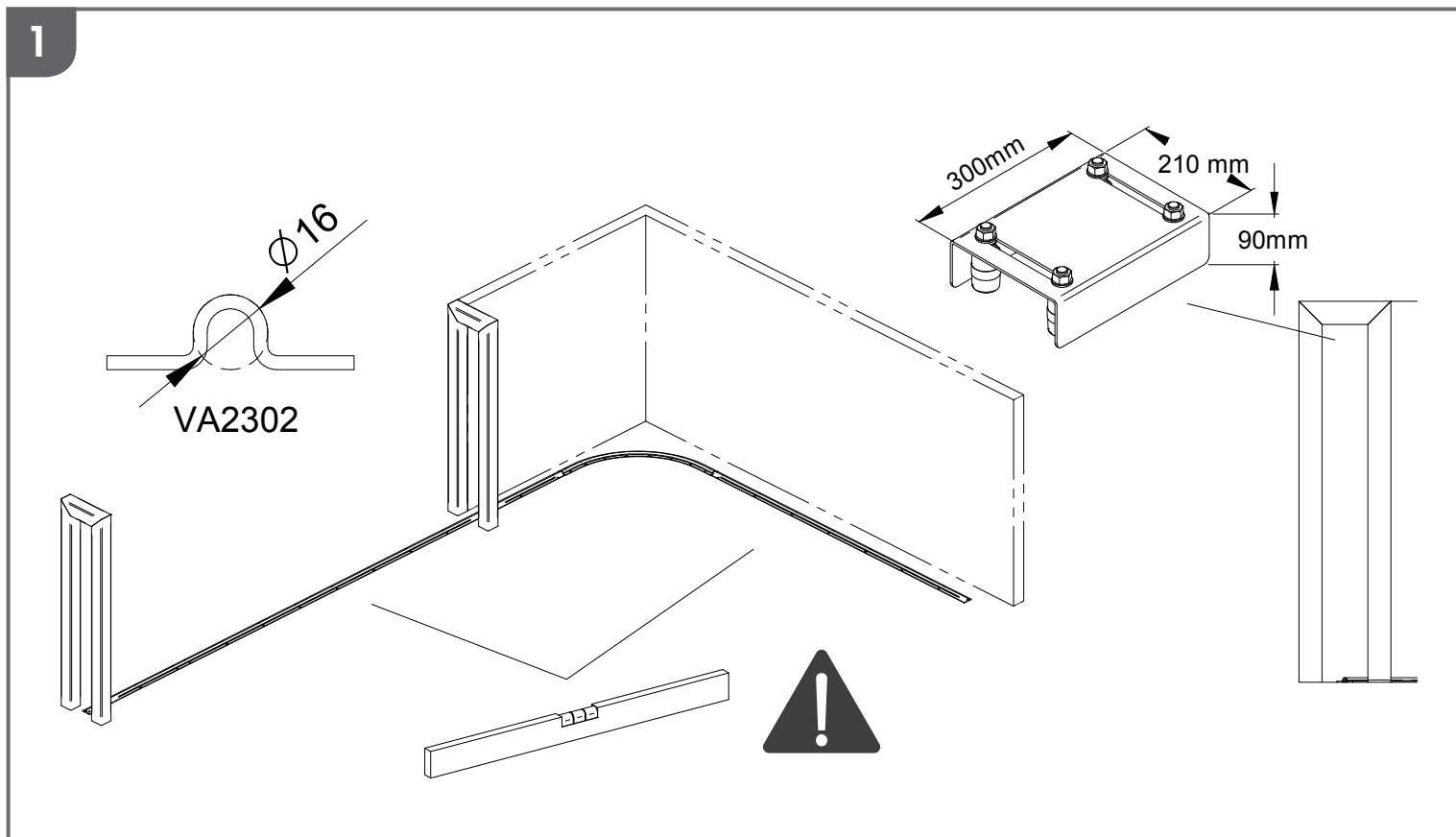



3

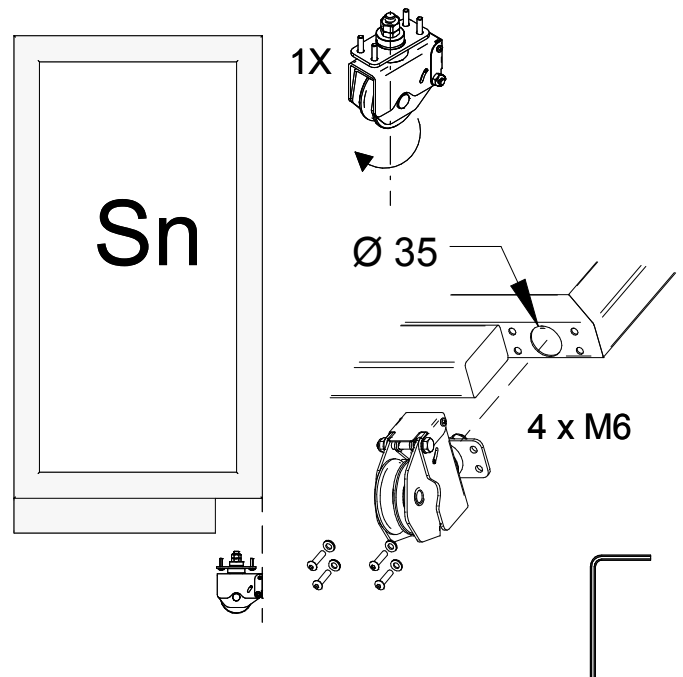
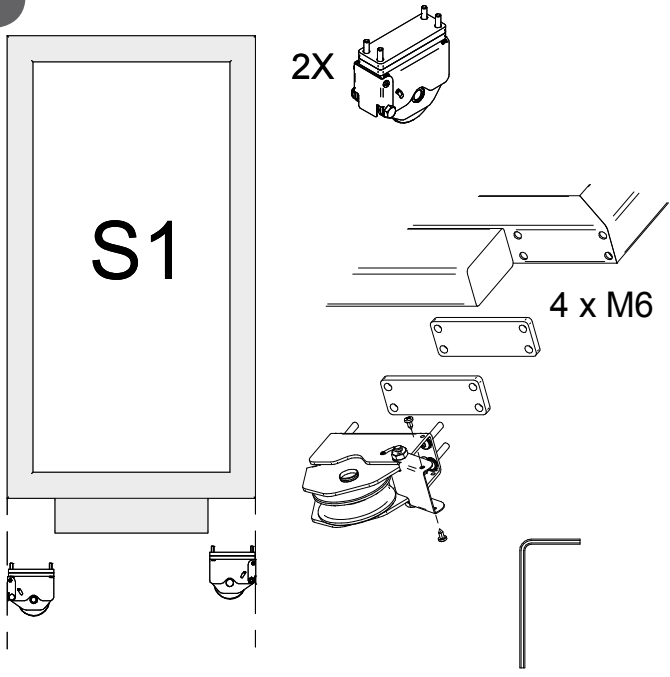

4

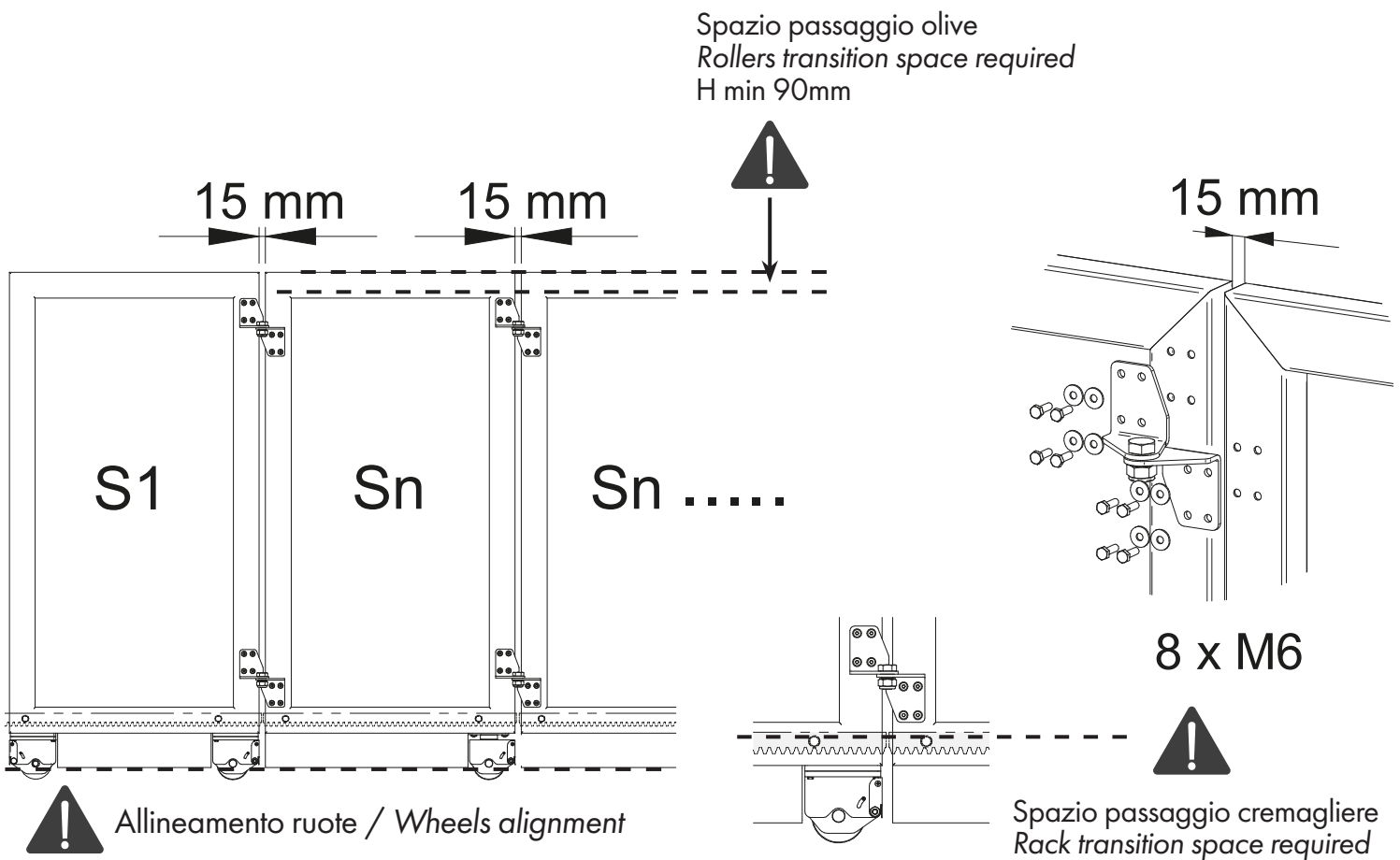



5

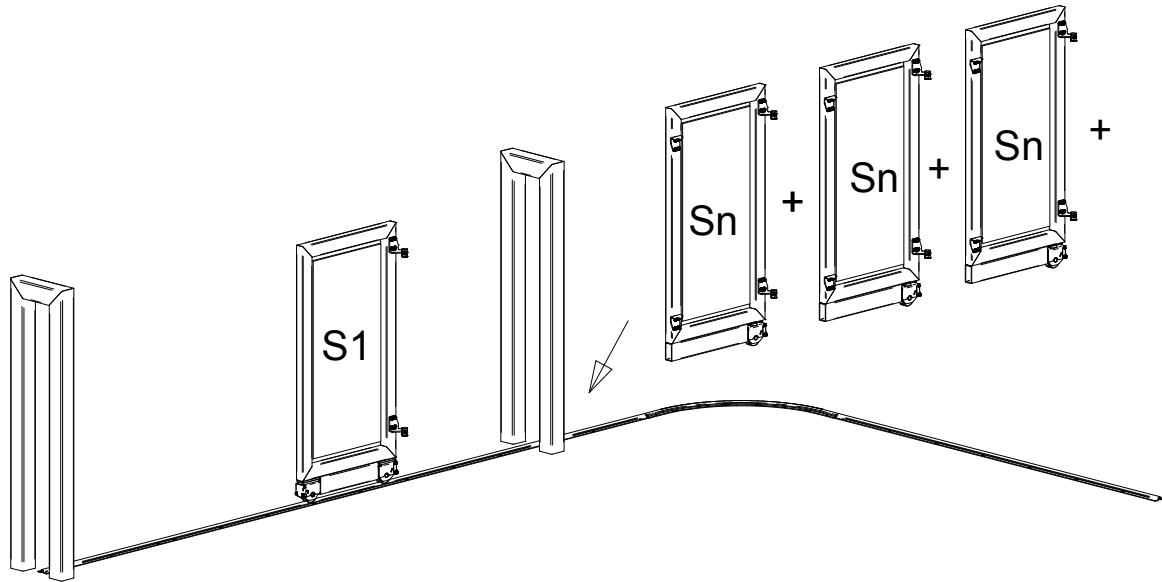

6

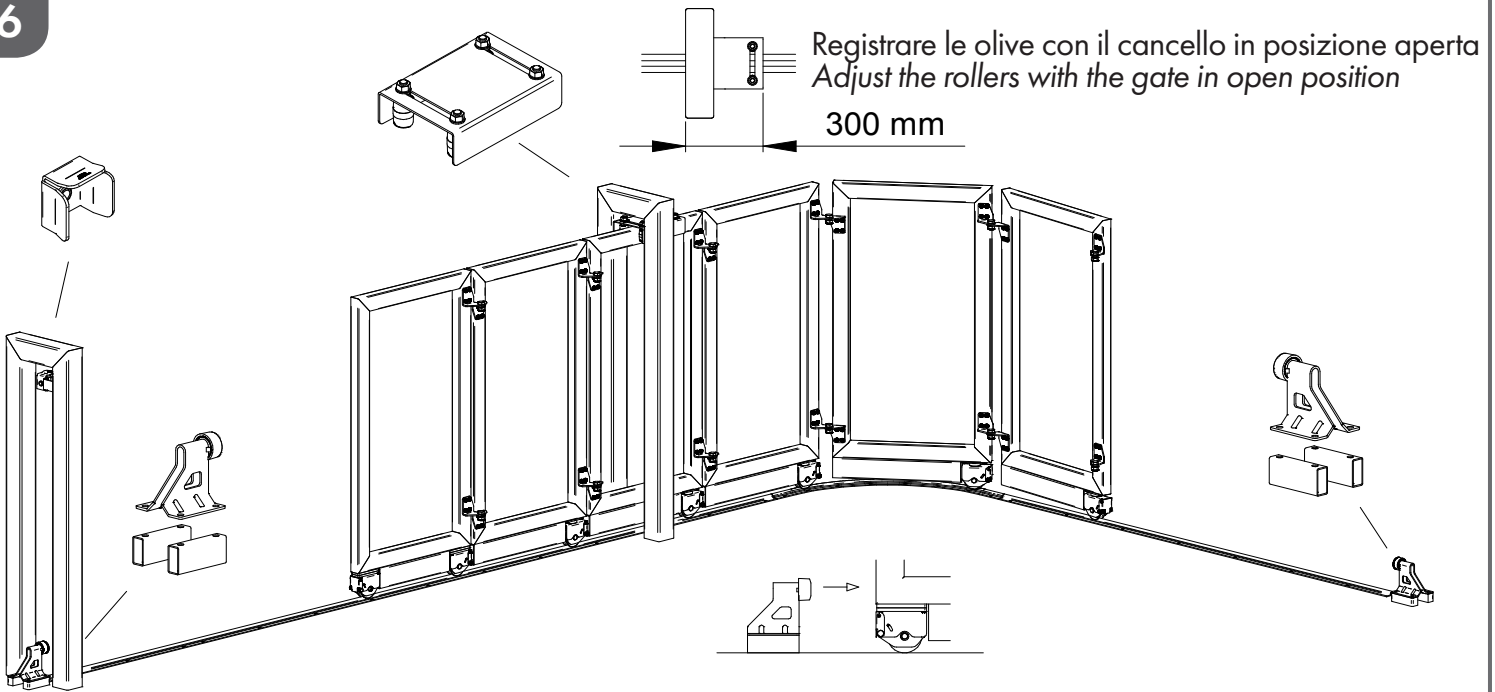

7

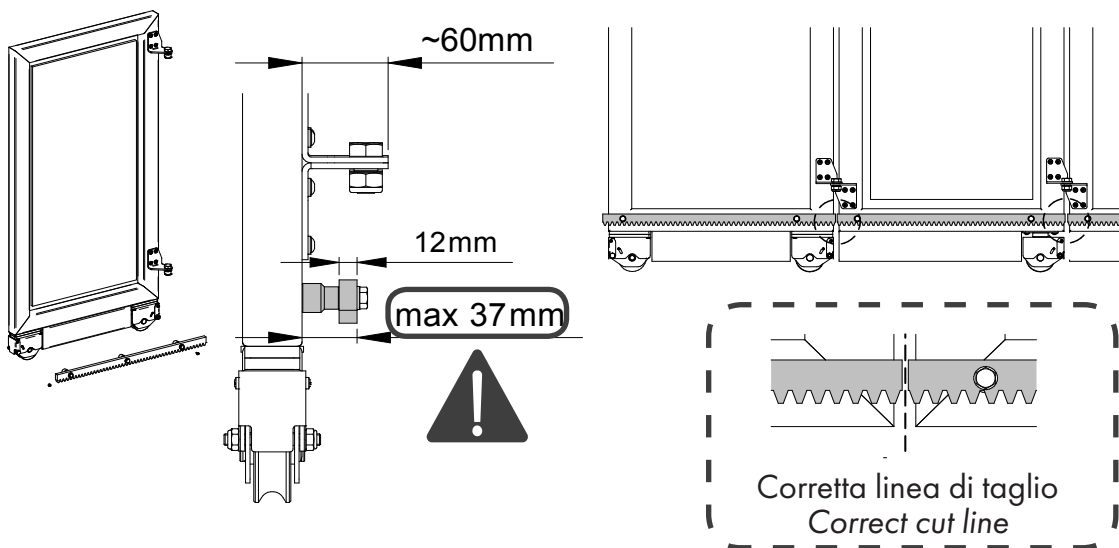



8



--- Zona di particolare rischio

Necessarie protezioni fisiche ed elettroniche

--- Dangerous area

Physical and electronic protections required

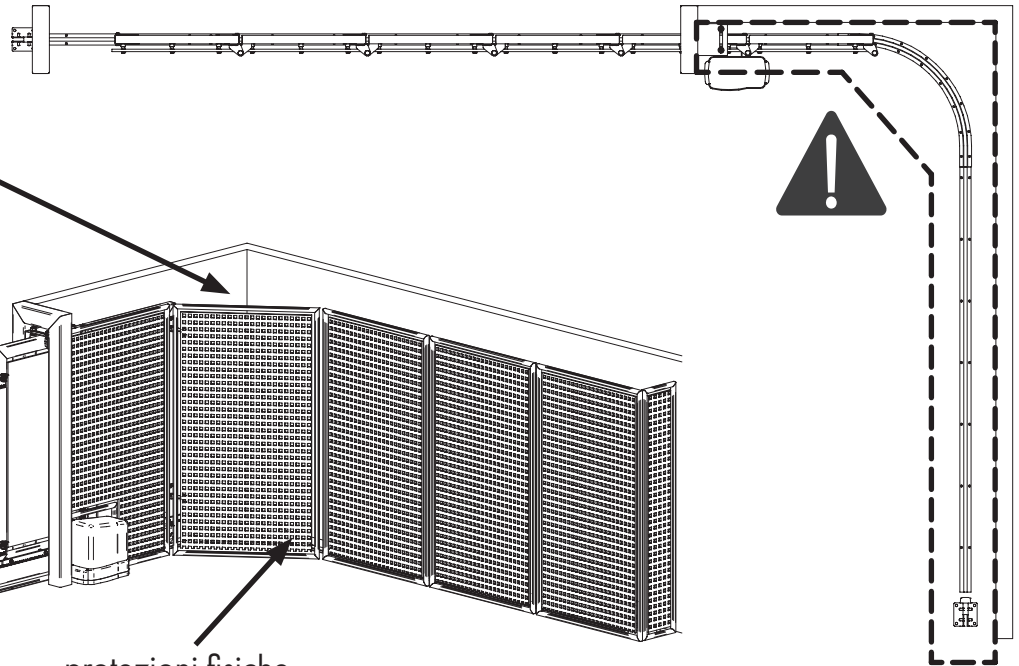
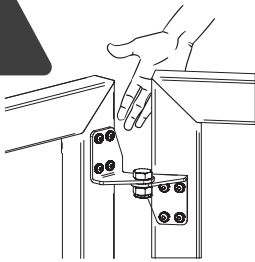

protezioni fisiche
Physical protections

MANUTENZIONE MAINTENANCE

1. Eseguire le verifiche di funzionamento manuale a fine installazione; controllare periodicamente che il sistema sia funzionante, privo di allentamenti e lubrificato (consigliato ogni 3 mesi e massimo 8000 cicli)
2. In caso di malfunzionamenti dovuti ad usura o urti accidentali, assicurarsi che tutti i componenti atti al sostegno del cancello e alla sua manutenzione siano integri. Se necessario procedere alla sostituzione.
3. FAC garantisce il corretto funzionamento del sistema esclusivamente con l'utilizzo di ricambi originali

Attenzione: Gli accessori compresi nei kit e l'installazione proposta fanno riferimento ad un esempio standard. Una installazione non conforme alla procedura illustrata e/o l'omissione delle corretta manutenzione potrebbero causare malfunzionamenti, compromettendo la sicurezza di persone e cose adiacenti. Verificare che gli accessori siano idonei all'opera specifica e dotarla dei necessari dispositivi di sicurezza previsti dalle normative vigenti.

Per ulteriori informazioni scrivici a : info@facsr.com

1. Perform all functioning inspections manually at the end of the installation; periodically check that the system is functioning, well lubricated and does not have any loosening. (We suggest a full examination every 3 months or after 8000 cycles).
2. In case of malfunctions due to wear or accidental impacts, make sure that all components apt to support the gate and its maintenance are intact. If necessary, proceed with substitution.
3. FAC ensures the system correct functioning only using original spare parts.

Attention: The kit included accessories and the proposed installation make reference to a standard example. An installation not in accordance with the illustrated procedure and the omission of the correct maintenance might compromise nearby things and people's security. Make sure that all accessories suit the specific work and make sure to use the necessary safety devices provided by current regulations.

For more information: info@facsr.com

KIT RADIUS – COULISSANT ARTICULÉ

Kit avec accessoires en acier galvanisé pour portails sectionnels / coulissants articulés

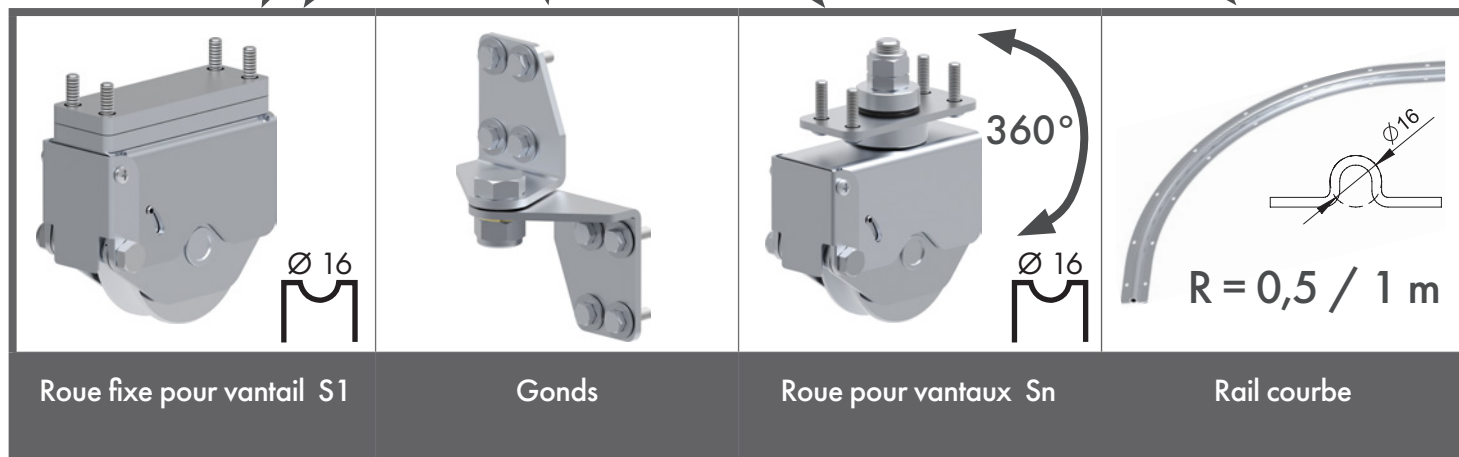
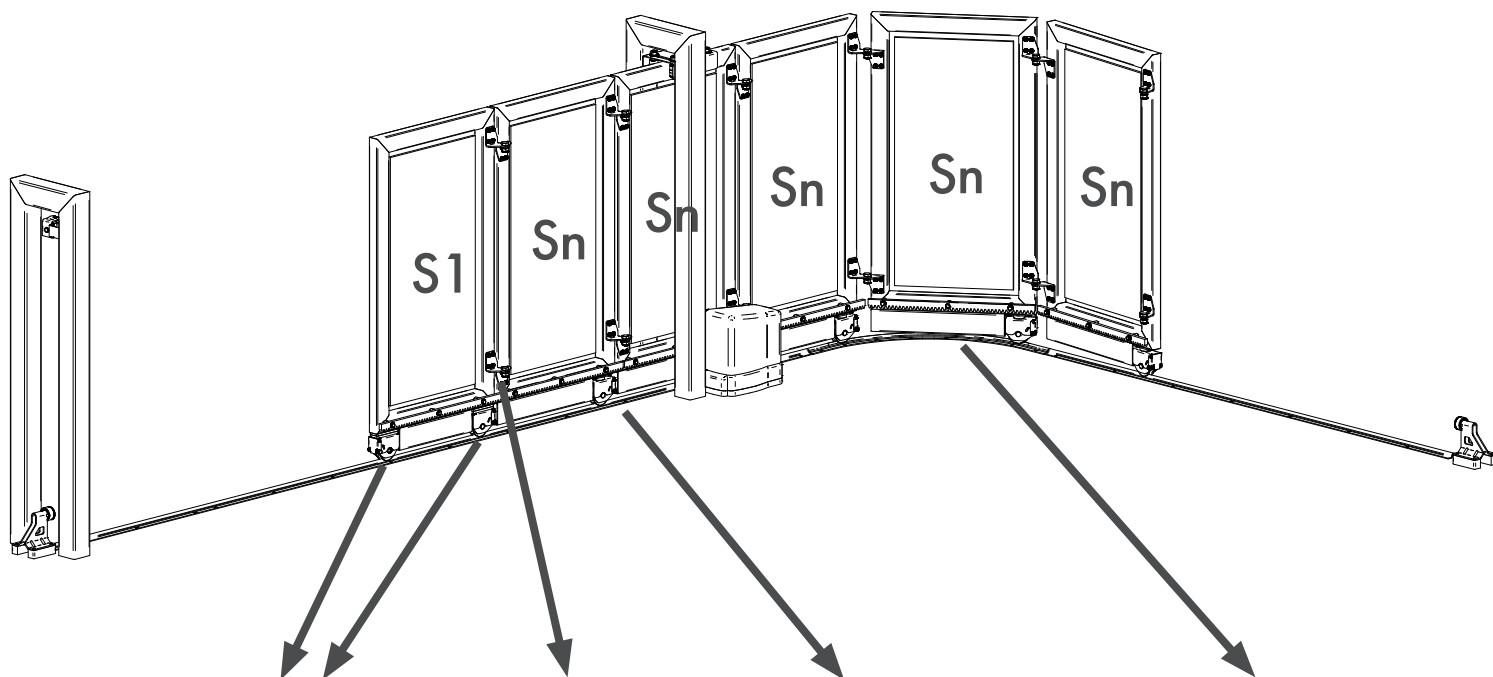

KA8103 KIT VANTAIL PRINCIPALE S1





KA8103.050	Rail courbe R 0,50 m Vantail de 0,4 à 0,75 m	<p>R = 0,5m</p>
KA8103.100	Rail courbe R 1 m Vantail de 0,4 à 1,5 m	<p>R = 1m</p>

KA8103.001 KIT VANTAIL SECONDAIRE Sn

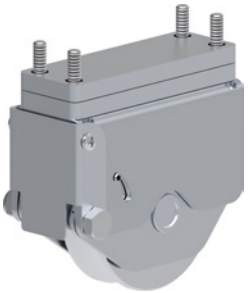

LISTE DE COMPOSANTS

KA8103.050/.100 KIT VANTAIL PRINCIPAL S1

<p>x2</p>  <p>Ø 16</p>	<p>x1</p> 	<p>x2</p> 
<p>VA1321.075</p>	<p>VA3205.B40</p>	<p>VA4112.125</p>
<p>x1</p>  <p>R = 0,5 / 1 m</p> <p>VA2312</p>		

KA8103.001 KIT VANTAIL SECONDAIRE Sn

<p>x1</p>  <p>Ø 16</p>	<p>x2</p> 	
<p>VA1322.075</p>	<p>VL4600.135</p>	



ARTICLES CONNEXES

 <p>VA2302</p>	 <p>VA4203</p>	 <p>VA6201 VA6202</p>
---	---	--



DIMENSIONNEMENT

POIDS VANTAIL	POIDS MAX PORTAIL	ÉPAISSEUR TUBULAIRE T
min 15 - max 100 Kg	500 Kg	min 40 - max 80 mm

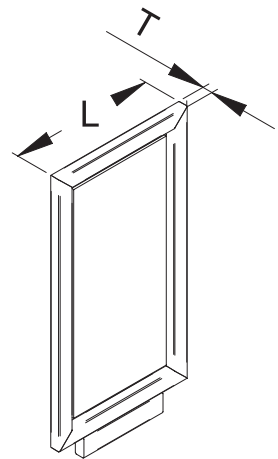
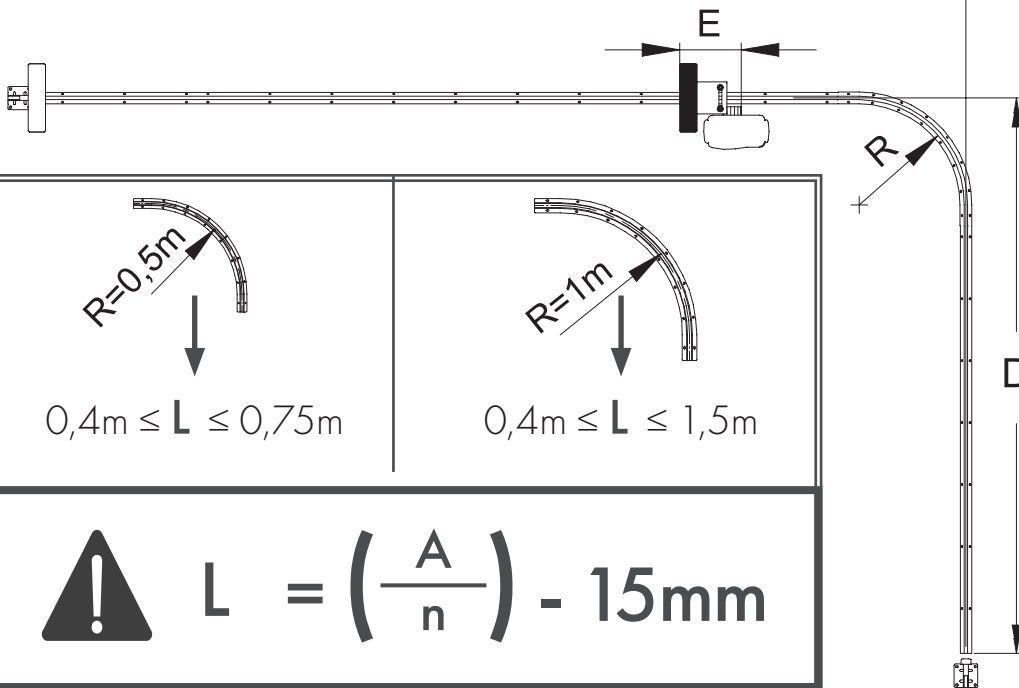
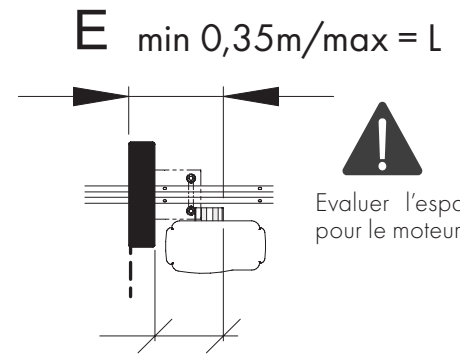
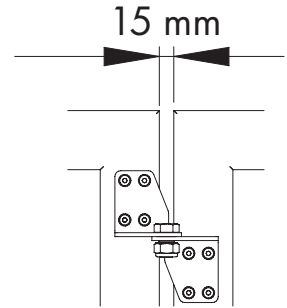
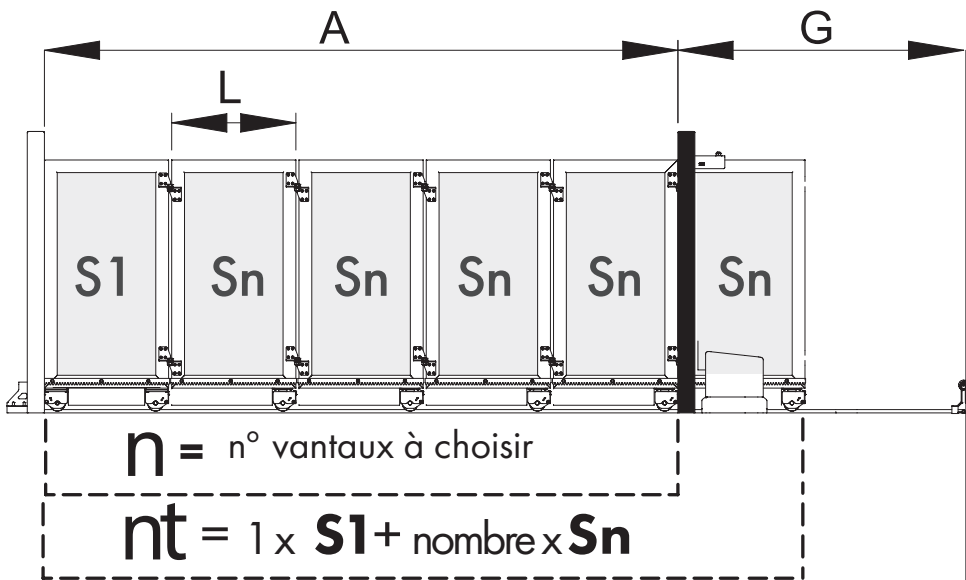

! $L = \left(\frac{A}{n} \right) - 15\text{mm}$

$G = L + E + R$
 $D = A - E - 0,2\text{ m}$

$G = L + E + R$
 $D = A - E - 0,4\text{ m}$



Attention:
Augmenter ou diminuer n pour obtenir des valeurs L compatibles.
Valeurs G min. réalisables en utilisant des vantaux courts et rails courbes 0,5 m. D dépend des valeurs A, L e du rayon R choisi.

LEGENDA

- A = Ouverture
- G = Encombrement arrière
- E = Distance entre le pivot du moteur et la colonne
- R = Rayon de la courbe
- L = Longueur vantail
- D = Encombrement latéral de la rail
- T = Épaisseur vantail
- nt = Nombre total des vantaux



NOMBRE DE VANTAUX ET ARTICLES À COMMANDER POUR RÉALISER LE PORTAIL

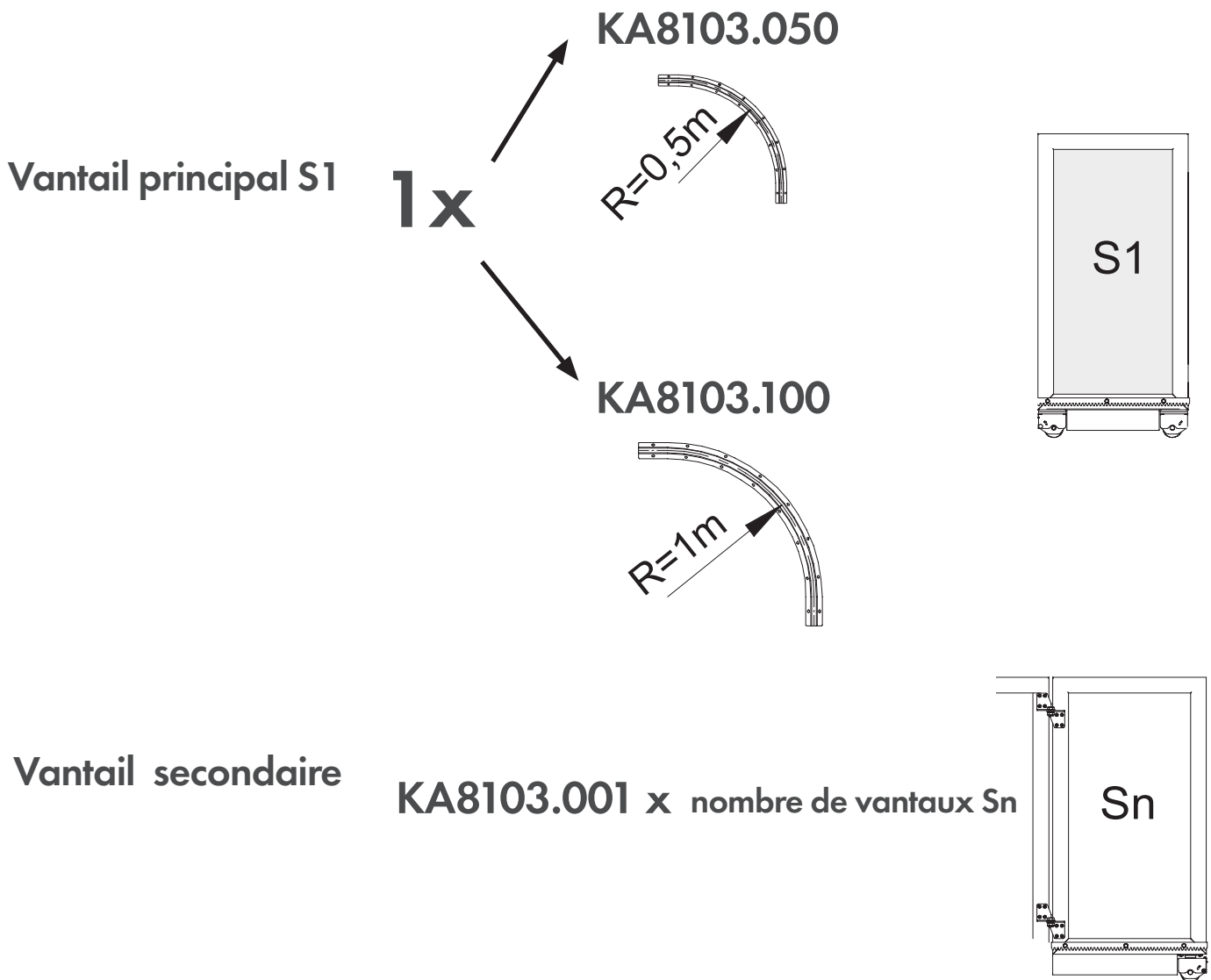



INFO TECHNIQUE

1. Important : l'installation de ce portail doit être faite sur un sol plat, sans bosses ni creux.
2. Pour portails motorisés il faut faire attention au positionnement, à la coupe et aux mesures maximales des crémaillères.
3. Pour portails motorisés il faut prévoir ponts de départ et arrêts lents. Vitesse max. = 0,18 m/s

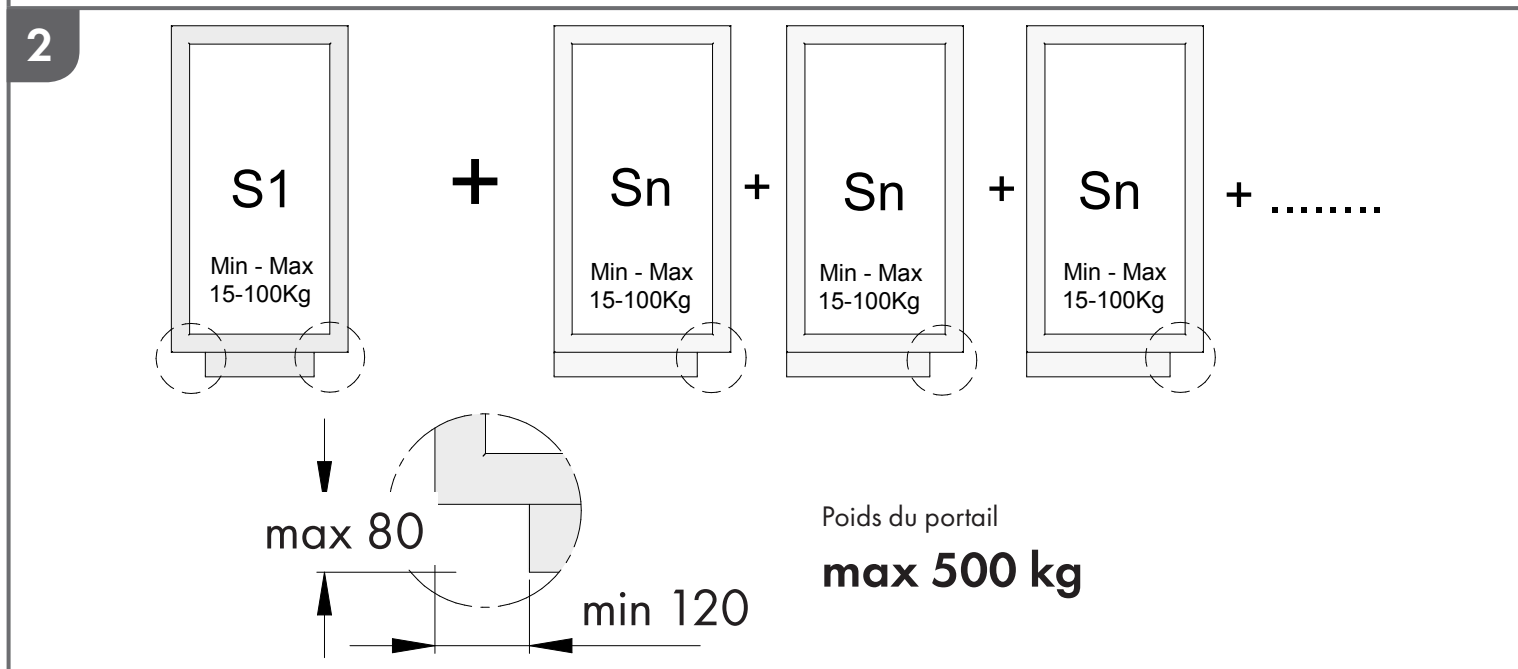
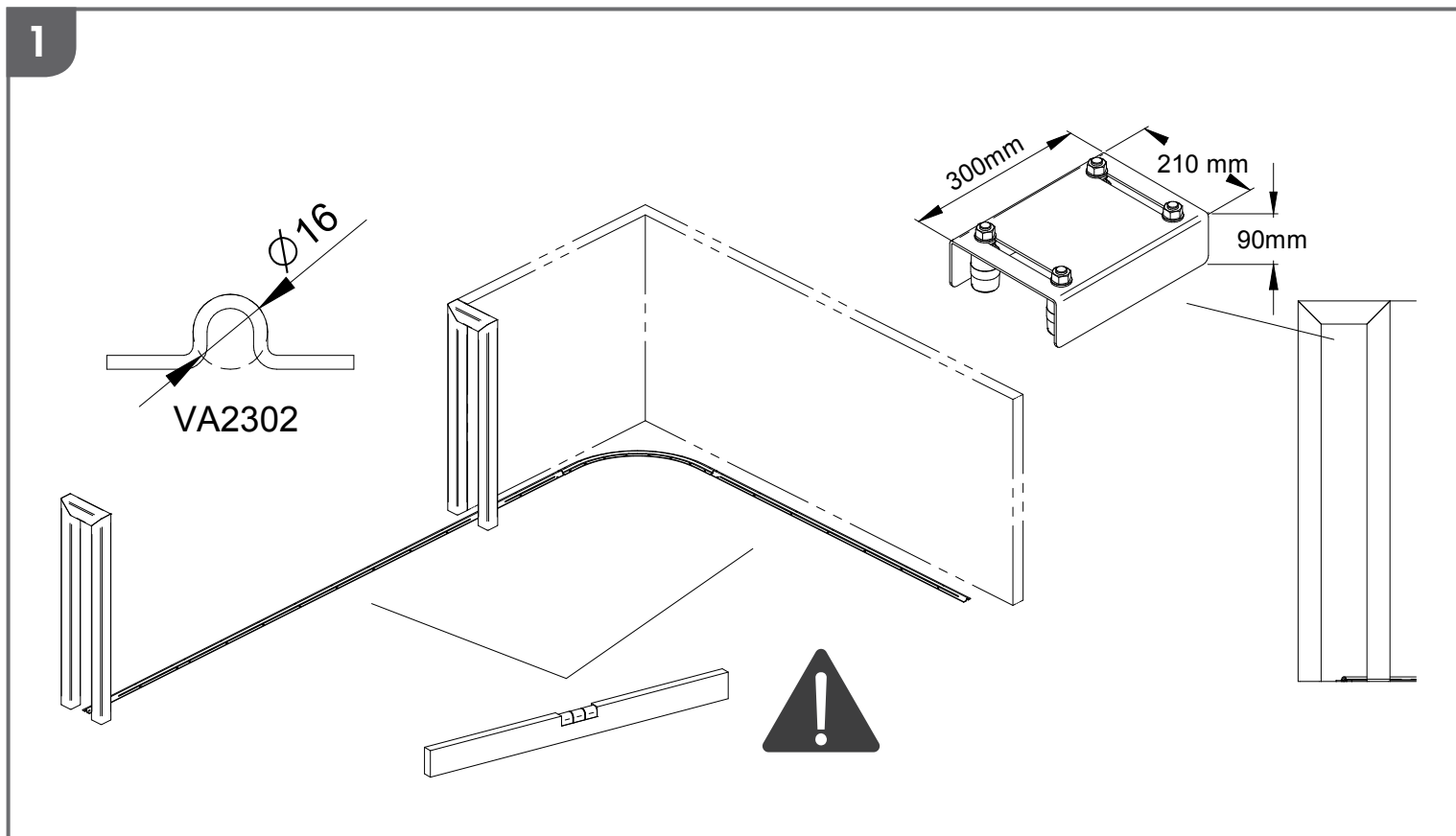

3

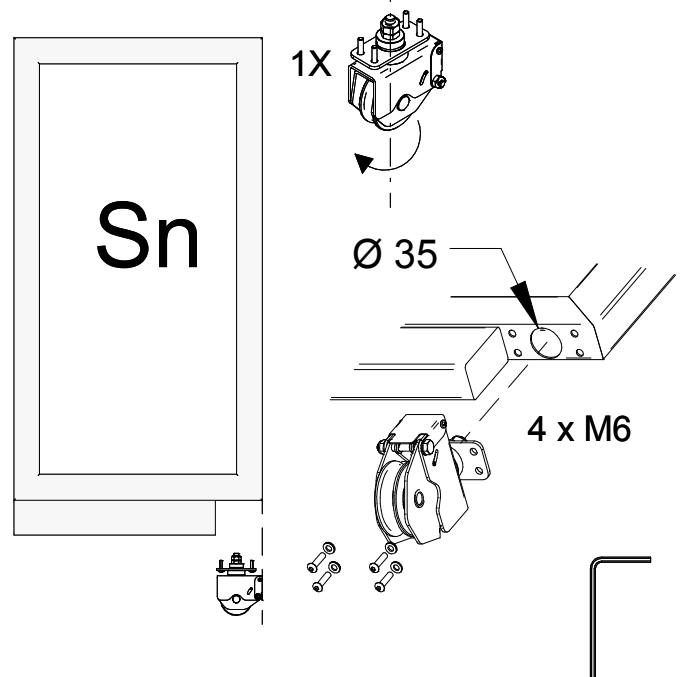
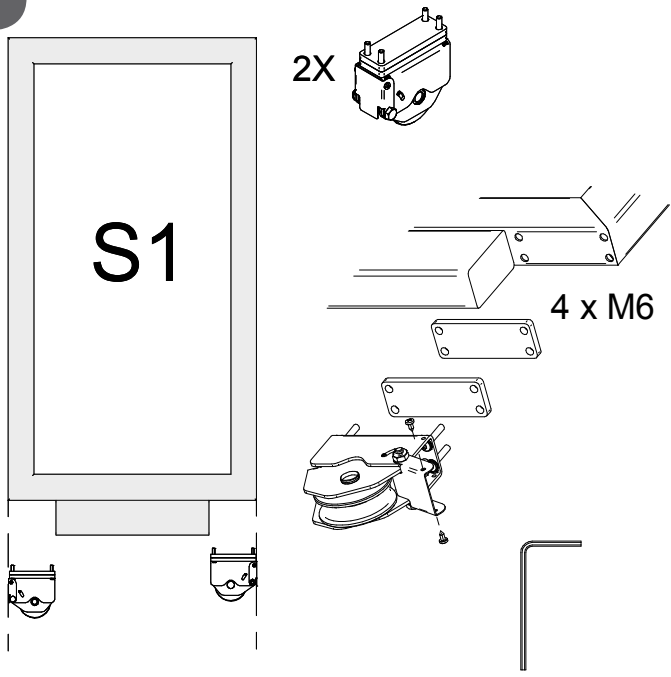

4

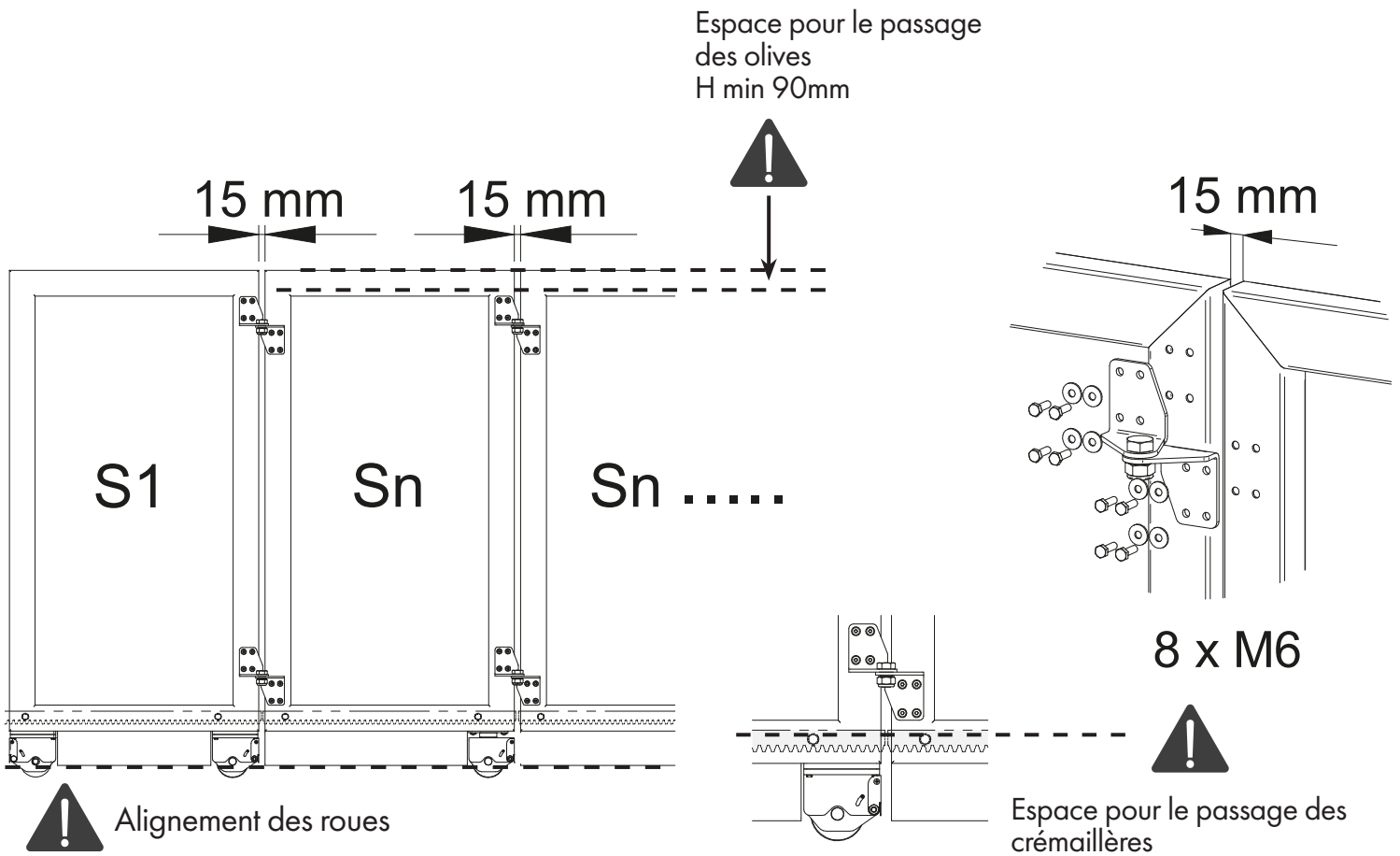

5

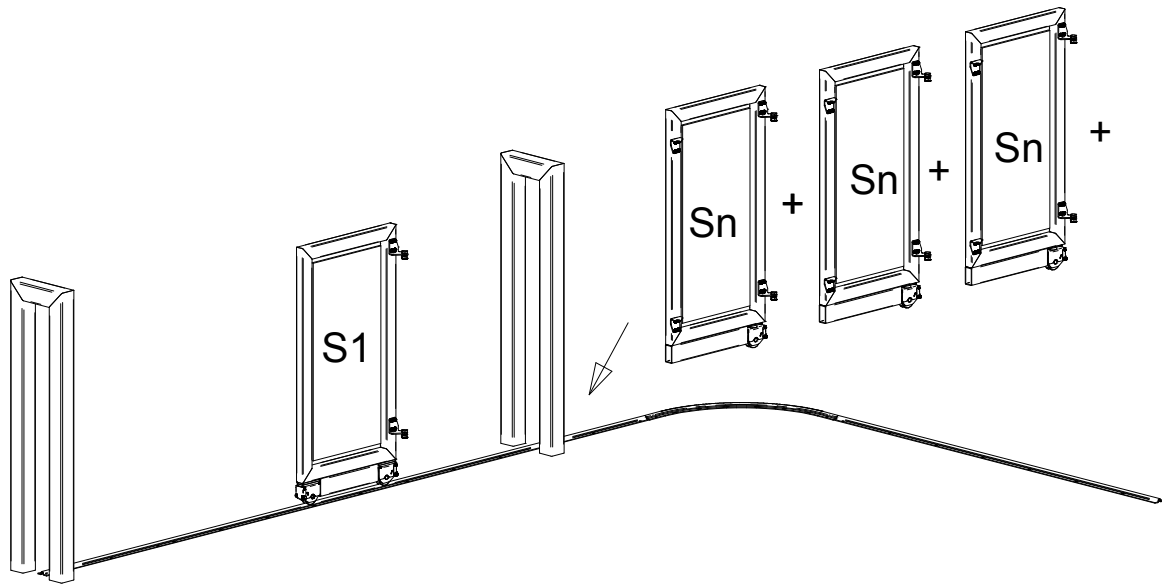

6

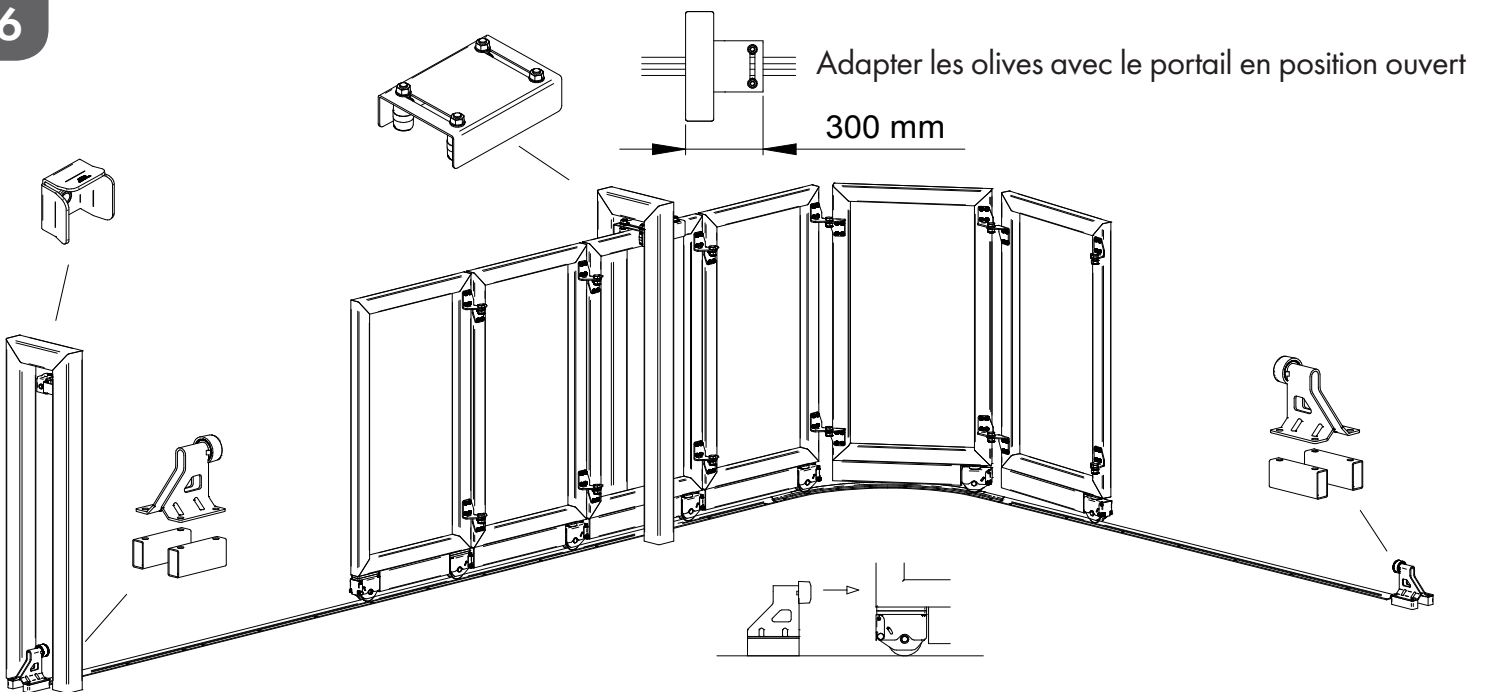

7

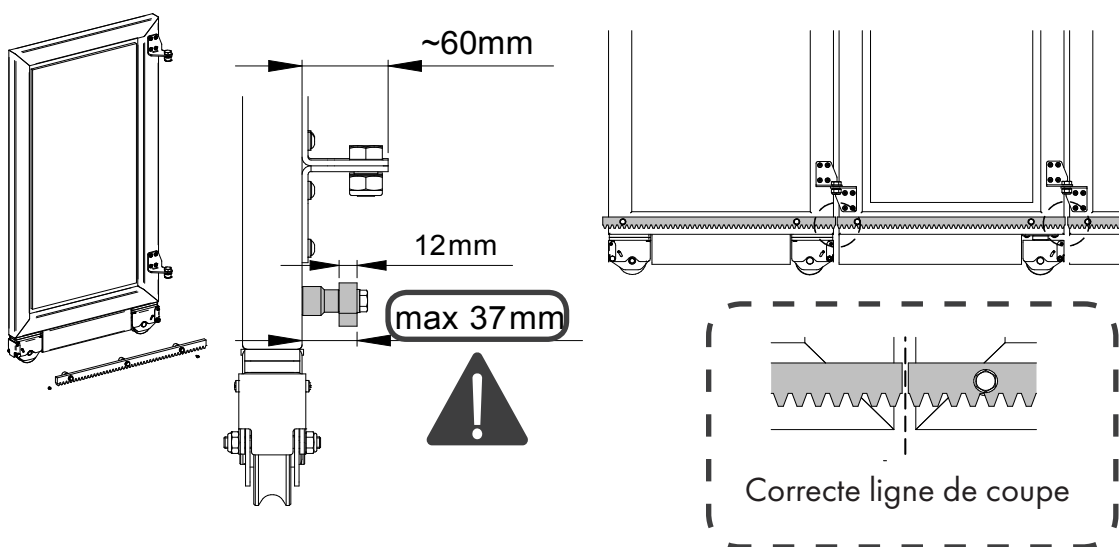



8

**--- Zone de danger**

Il est nécessaire d'utiliser protections physiques et électroniques.

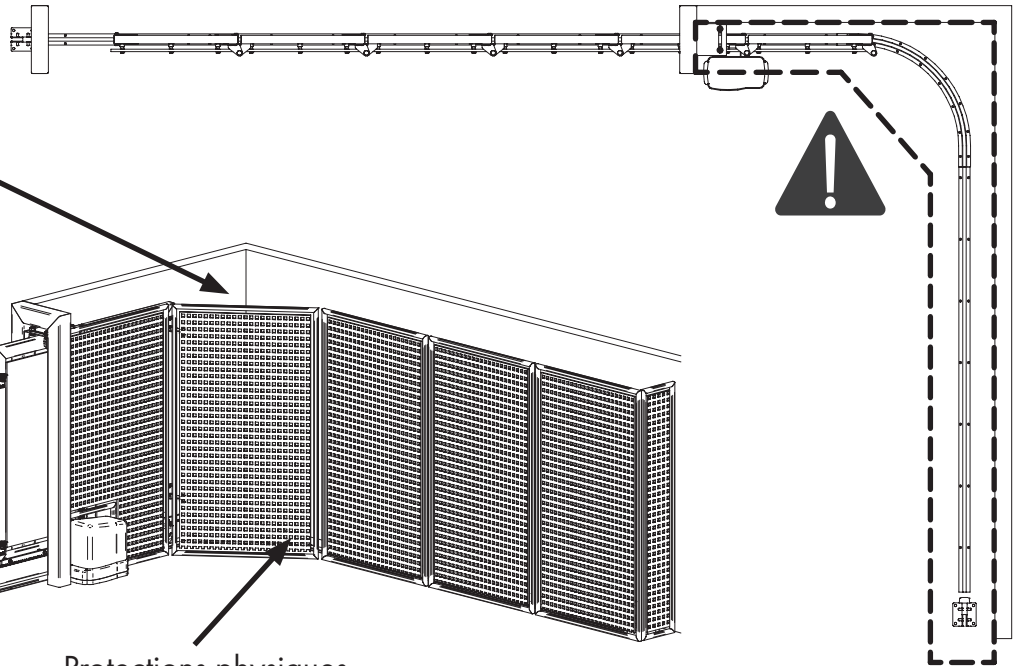
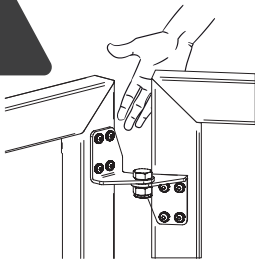

Protections physiques

ENTRETIEN

1. Effectuer les contrôles de fonctionnement manuels à la fin de l'installation, s'assurer qu'il n'y a pas de pièces desserrées et garder toujours le système bien lubrifié. Contrôler au maximum tous les 8000 cycles ou tous les 3 mois.
2. En cas de défaut de fonctionnement dû à l'usure ou à des chocs accidentels, on doit s'assurer que toutes les pièces du portail servant à soutenir et activer le portail soient en bon état et éventuellement les remplacer.
3. FAC garantit le fonctionnement correct du système uniquement si des pièces de rechange d'origine sont utilisées.

Attention : Les accessoires qui composent les kits ainsi que la proposition d'installation se réfèrent à un exemple standard. Une installation non conforme à la procédure indiquée ou la non-exécution des opérations d'entretien correctes, peuvent provoquer un dysfonctionnement du portail, en mettant en danger la sécurité des choses et des personnes se trouvant à proximité. Vérifier que les accessoires soient appropriés à l'ouvrage spécifique et l'équiper de tous les dispositifs de sécurité prévus par la réglementation en vigueur.

Pour des informations supplémentaires vous pouvez écrire à : info@fac srl.com